

APPLICATION:

PRODUCT NAME:  
CHECK VALVE 1/2" FEMALE

JOB NAME:

SPECIAL CONFIGURATION  
 CHECK BASE MODEL AND OPTIONS

QUANTITY:

ITEM NO.

MODEL:  
 2936-9000

OPTIONS OR MODIFICATIONS:  
 OTHER \_\_\_\_\_

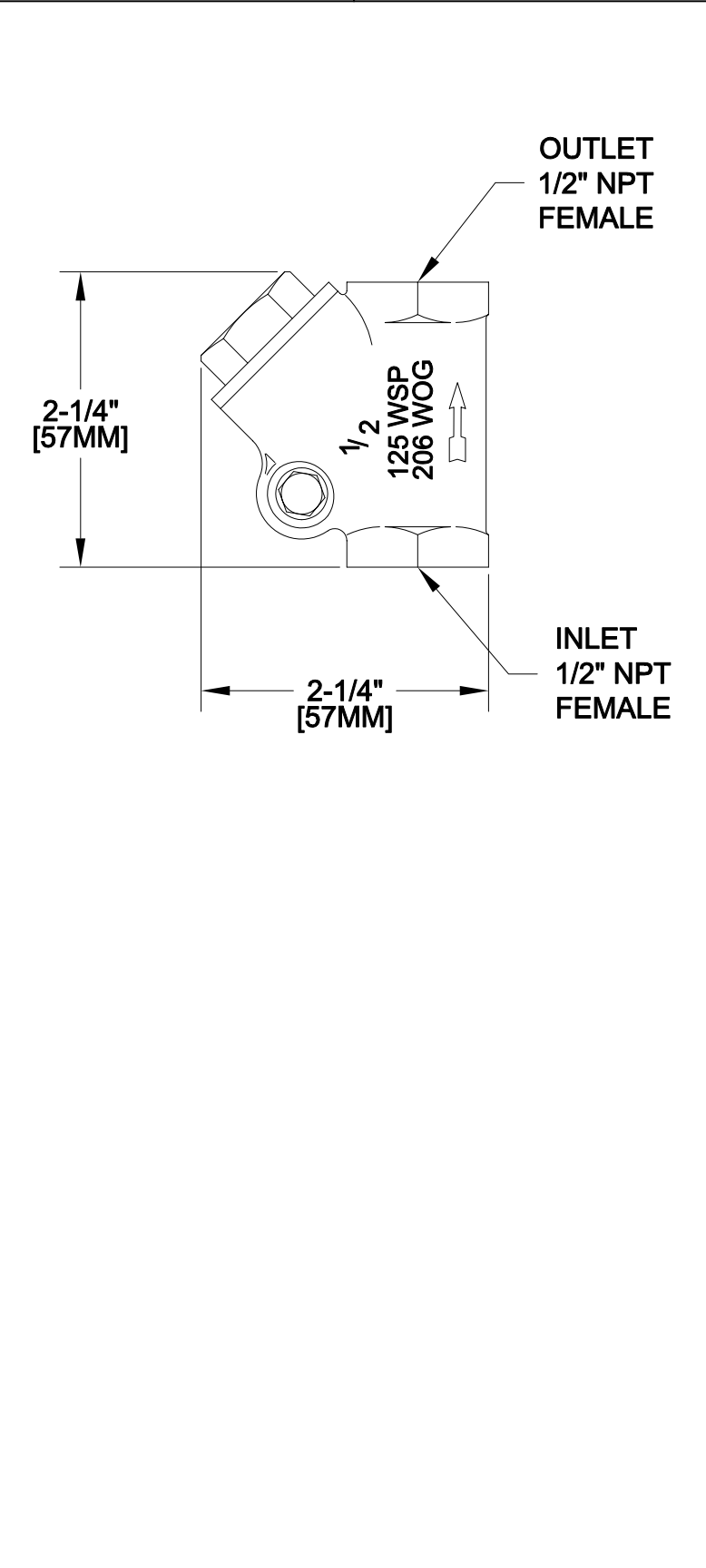

FEATURES  
\* BRASS BODY  
\* ALLOWS FLUID FLOW IN ONE DIRECTION ONLY

SYSTEM LIMITS  
\* TEMP: 40°F MIN. TO 140°F MAX.  
\* PRESSURE 150 PSI MAX.

SHIPPING WEIGHT  
\* 0.75 LBS